



Future Implications of IPv6

“Accessorizing IPv6”



Preston Marshall

Defense Advanced Research
Projects Agency (DARPA)
Advanced Technology Office
pmarshall@darpa.mil





The Future IPV6 Wireless Problem

From Access Points to MANETs!



- **Real Mobile Wireless Networks Will Not Behave as Office Networks Do!**
 - Wireless Connectivity Disrupted by Terrain, Weather, Interference, Access Scheduling, ...
 - Early Experiments Evidence Episodic Connectivity
- **Internet Technology Based on Relatively Static Network Topology**
 - Must Distribute Highly Dynamic Accessibility of MANET, Multi-Routed (Fiber, SATCOM, Terrestrial RF, ...) Networks
- **Move to Support of “Infrastructureless” Architectures**

Toughening the Radio is Not the Answer!
Must Toughen Up the Network Itself!



Some Key Technologies



- **Bundling** – Handle Intermittent Operation by Organizing information into “Bundles” that can be Delivered by Network (Delay Tolerant Nets)
- **Fuzzy Scheduling** – Making Network Routing Decisions in the Presence of Uncertainty about Available or Optimal Paths
- **Policy Cognitive Operation** – Moving Intelligence into Network to Make “Best” Choices on Delivery
- **Deferred / Hierarchical Address Binding** – Enable Network to Deliver Traffic Without End to End Address and Routing Info
- **Connectionless Networking** – Optimizing Network Protocols for Operation in Energy Limited Modes



How Is DTN Different than the Internet?



Internet

DTN Enhancement

Scope

Must have Global Awareness of All Nodes/Routes

Operate with Only Local Node/Topology Awareness

Connectivity

Must be End to End

May be Episodic

Network Complexity

Extremely Simple

Introduces Very Complex Elements

Network Delivery Responsibility

None – Upper Layers Must Assure Delivery

Bundle Intermediaries take Delivery Responsibility

Fundamental Unit

Data-Driven Packet

Information-based Bundle

Trust

None

All Bundles Include Certificate



How is Intermittent Connectivity Accommodated Currently?



- Most cases: *It's Not.*
 - UDP used to avoid TCP timeouts
 - Custom reliability mechanisms with dubious benefits
 - Persistent Retransmission – **Power Inefficient**
 - If Only Single Intermittent Link – **Pretend its an Email!**
- Accommodation, if present, ad hoc and brittle:
 - Vendor/program Unique solutions
 - Applications lurk, waiting for connection opportunities (e.g. spyware) – **excessive power** in wireless environment
 - Existing services such as Mail (SMTP) and News (NNTP)
- No notion *ever* of scheduled connectivity and routing
 - Even fewer notions of predicted connectivity

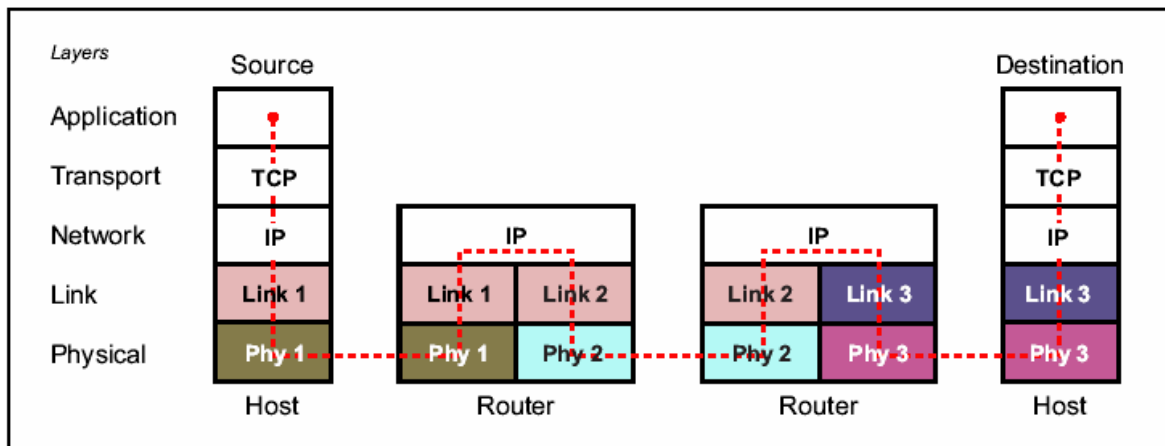

IP (UDP or TCP) Can Only Work if there is an IP Continuity Between Nodes for Duration of Transfer

DTN can operate over non-IP Paths and Hold Data During Periods When All of Path is Not Available

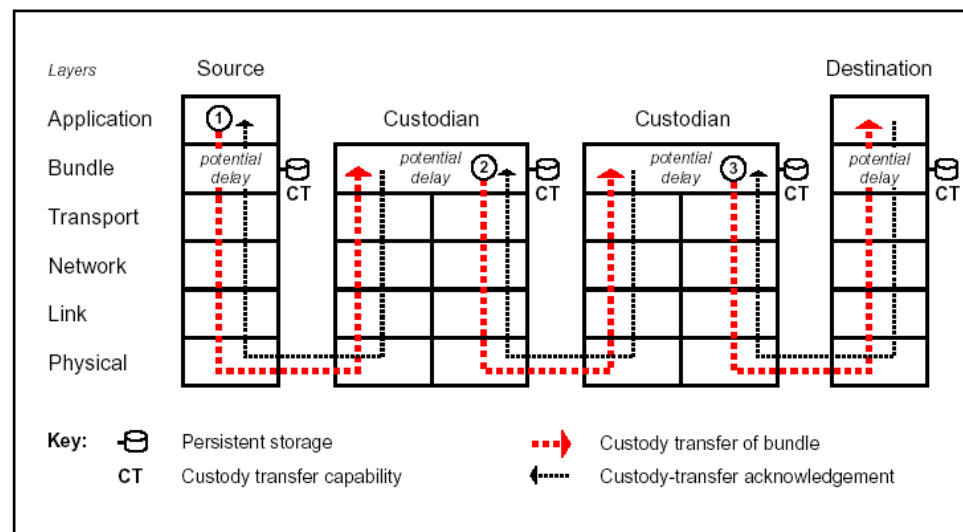



DTN vs TCP Performance

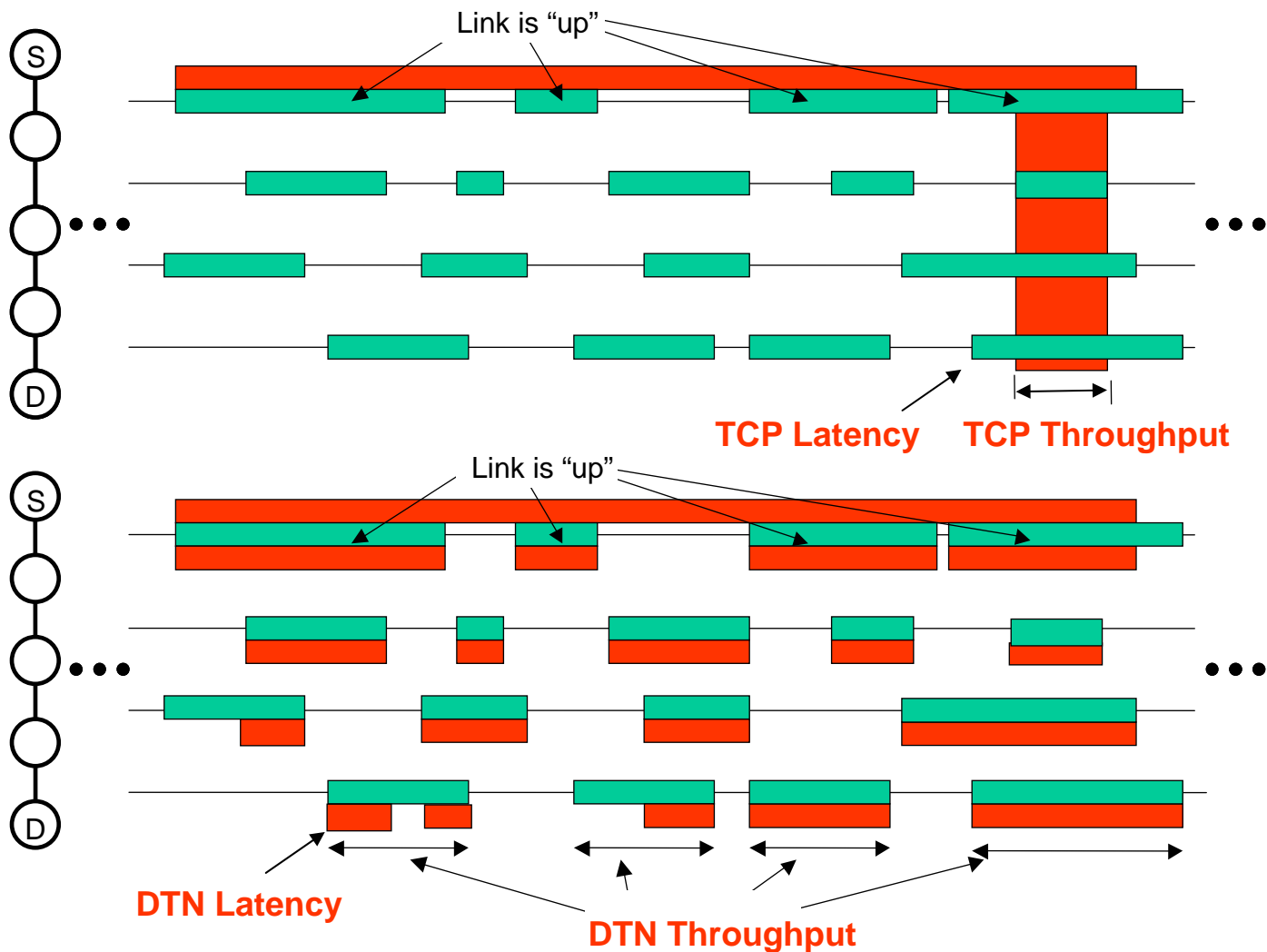

- Most MANET Research Focused on Routing within the MANET “IntraNet”
 - Assumed MANET Network Connectivity to Rest of Internet Static
- Integration of Tiered, Mobile Ad Hoc Networks with Large Scale Routing Networks Not Demonstrated or Understood
 - Complex Problem -- When MANETs Change Subnet Structure /Points of Access to Network
 - Move from SATCOM to Terrestrial Point of Presence
- Informing All Routers and Name Servers of Each Change in Topology Not Scalable Approach With Dynamic or Episodic Connectivity

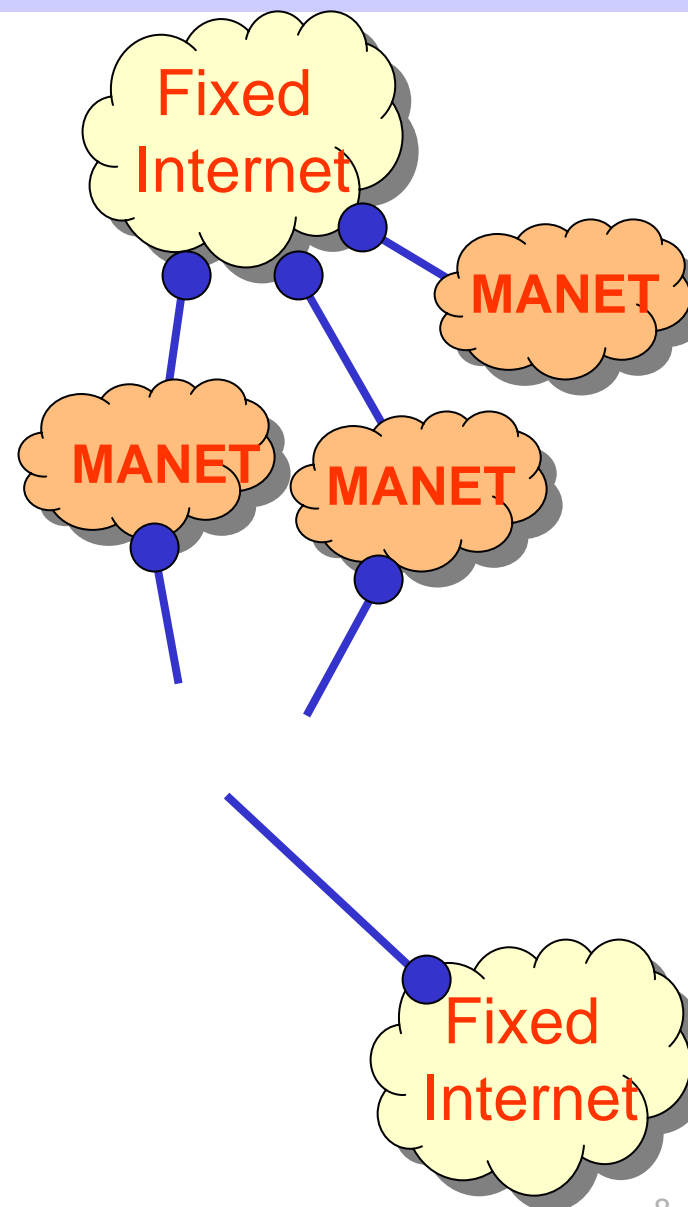



Technology Challenges

Bundle Layer



- Develop Technology for Custodial Transfer Across Network
- Demonstrate Stability in “Deterministic” Operation
- Security -- Develop Certificate “Trust” as Minimum
 - Confidentiality -- Develop Agent-Based Mechanism for End to End Key Formation (Existing Technology Not Feasible if Network not Connected)
- Multicast – Extend Delivery and Security Architecture to Multiple Addressees
- Incremental Authentication for “Cut Through” Delivery

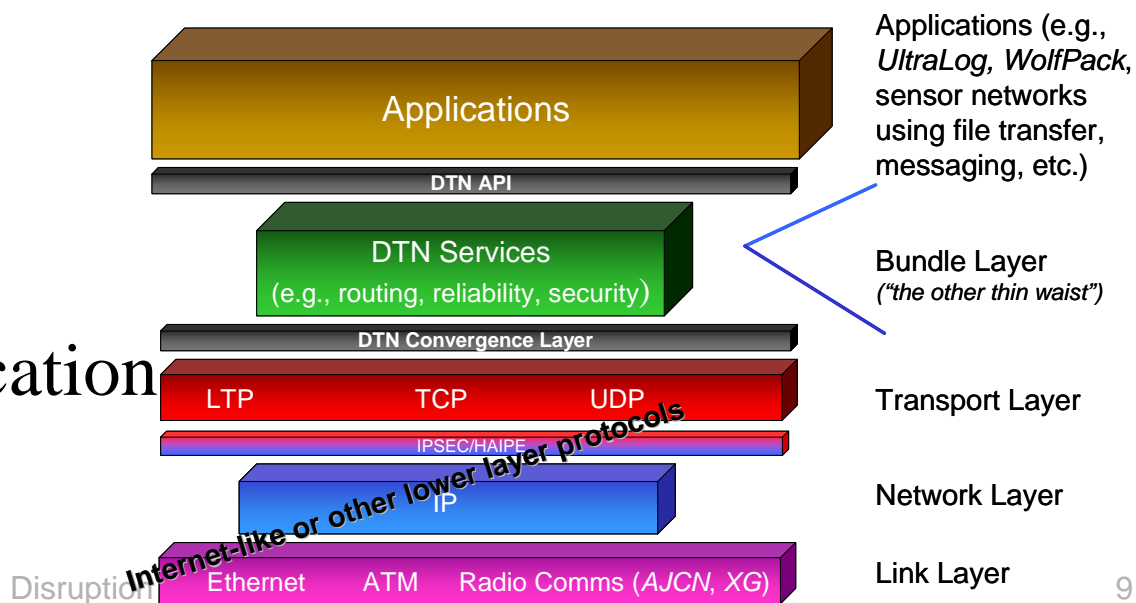



Technology Challenges

Fuzzy Scheduling



- DoD Technology Needs More Complex than NASA
 - NASA IPN Bundling Concept Based on Celestial Mechanics
 - Highly Predictable (Kepler, et al)
- Military Applications Have Wide Range of Scheduling
 - Some Are Somewhat Predictable
 - UAVs, UGS Operation, Vehicle Movement, ...
 - Some Not Predictable At All
 - Combat Contact, “Mote” Movement
- Need A General Theory of Route Scheduling
 - Replace Existing Internet Single “Shortest Path” with Multiple Hypothesis Routing, Replication, and Bundle Processor Coordination
 - Examine applicability of Epidemic, Gossip Techniques, Commodity Flow Analysis principles, Bayes Nets, ...
 - Awareness of All Potential Delivery Assets
 - Cost, Utility, Power, Opportunity, Perishability Security Trades

**Extend Current Network Thinking to
non-Deterministic Routing Decisions**



Technology Challenges Policy Cognitive Operation



- Choices of Routing, Storage, Multiple Replication Highly Complex
 - Classical Approach – Develop Large Code-Based Algorithm Set
 - Limited Extensibility to Unforeseen Uses
- Proposed Approach – Adopt Cognitive Technology to Provide Goal Seeking Behaviors
 - Use Ontology (DAML/OWL) Framework to Control Operations of Bundle Mechanisms
 - Complex Interactions Bounded by Capability, Policy, Probability, ...
 - Allow Different Users of DTN to Extend DTN by Loading Policies via DAML Framework
 - Link Provable Assertions to Network Behaviors
 - Similar to JAVA Extending Web by Adding Behavior – without IA Risk
 - Policy Metaphor Resolves Inconsistencies between Multiple Sources
 - *Fundamental Technology for Extending Networks* After they Are Developed
- When Successful, Basis for Migration of Many Network Operations Cognitive Processes



Cognitive
Networks

**Cognitive Networks Next Technology
Hurdle for Managing Complex Networks**



Why Policy Based?



- Leverage Flexibility in Smart Nodes (Radios, Routers, . . .) to Be Even More Controllable
- Allow Multiple Layers, Applications, Users, Messages, ... to Impact How the Node Operates
- Allow Extension of Capability Without Having to Load Multiple Sets of Software
 - Virus, Trust Issues
- Allows for Uncoordinated Development of Policies with Integration only at Execution Time
 - Can Resolve Conflicts rather than Crash!
 - For XG, Regional and National Authorities, “Band Owner”, Radio Builder, Spectrum Manager
- Formal Methods Make for “Provable” Behavior



Policy-Based Controls



- Systems Often Being Developed In Advance of Policy Framework
 - Implementations Must Fit With National And International Regulations
 - Algorithms Must be Adaptable
 - Regional and operational situations
 - Evolving policies
- Policy-Based “Metalanguage”
 - Translates Policy Rules Into Node Behavior Controls
 - Decouples Technology From Management Process
 - Control Operating Rules Based on Policies and Situations

Policy-Based Controls Will Draw on Practices & Methodologies Currently Employed Manually by System Managers



Why Semantic Web for Networks?



- Semantic Web Constructs have the right set of features, for example:
 - Reification (make statements about statements)
 - Enables policy rules governing other policy rules
 - Inheritance (classes reduce need for enumeration)
 - Rules Need Extend Only Portion of the Knowledge
 - Inference (can avoid explicitly stating what's derivable)
 - Uses Class Structure to Infer Knowledge
- Set Theoretic – Describes Conditions, Not Process: Combines in Any Combination (User, Service, Physical Layer, ...)
- Allows Multiple Sources of Policy to be Integrated and Applied
 - Code-Based Allow Only One, Web Supports Many
- Being Standardized As OWL By The W3 Consortium
 - Combines US (DAML) and EU (OIL) efforts



Technology Challenges

Deferred and Hierarchical Binding



- IP Built On Assumption of Stable Routes and Network Presence
 - Need Technology to Allow Nets to Move Connectivity, Change Internal Structure, or Appear and Disappear, and “Hide” Structure
 - IP v6 Enables Million times more Addresses!
- Deferred Binding
 - Delays Associating Bundle to Specific Address
 - Destination May not Even Be Resolvable (Present) at Time of Message Initiation
 - Allow Address to Change During Interaction
 - Allows for Role-based Addressing and Multiple Internet namespaces
- Hierarchical Binding
 - Layered Resolution of Address and Routing Info
 - Consistent with Military Organization, and Original Intent of IP DNS
- Believe Extensible to IP-Based Networks

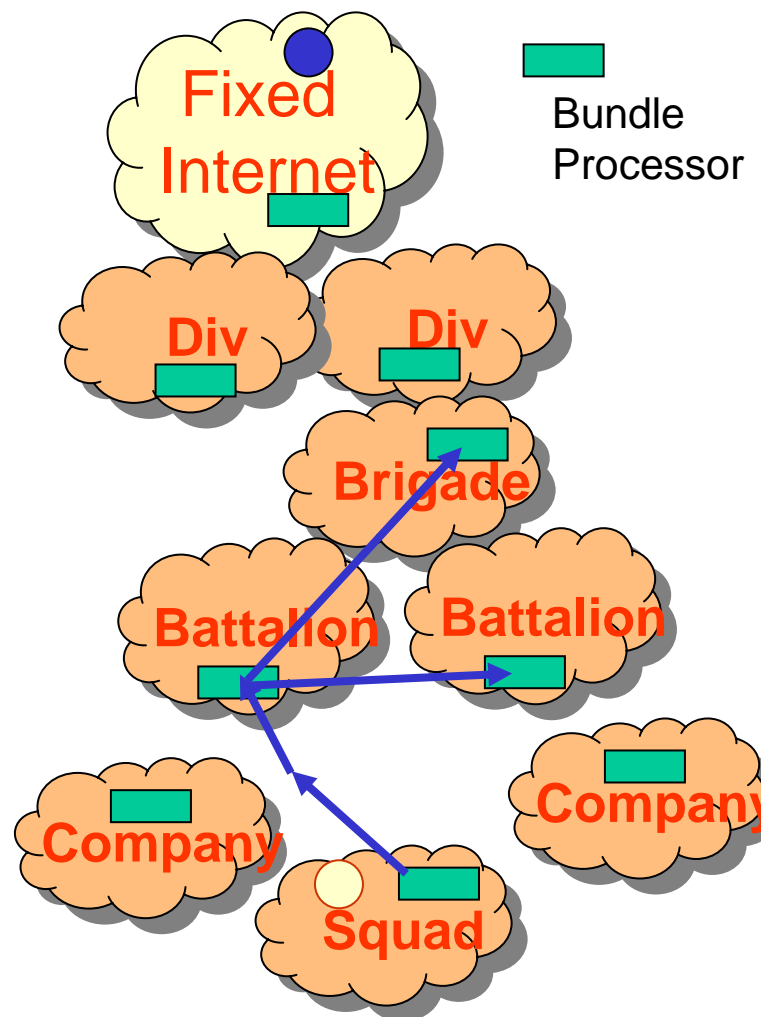

Fundamental Technology Applicable to Any Dynamic Network



Connectionless Networks



- Required Technology to Deploy Large Number of Autonomous Low Duty Cycle Radio Devices
- Orders of Magnitude Decrease in Required Power & Signature
 - Potential Battery Life Extension of 1,000 times!
- Scalable Architecture for Range of Networks
 - Dense (Short Range)
 - Widely Distributed (Medium Range)
 - Very Proliferated (Over >100,000 Radios)

**Challenge Assumption That Wireless Systems
Should Look Like Wired Ones**



Connectionless Networking

Relative Energy Use

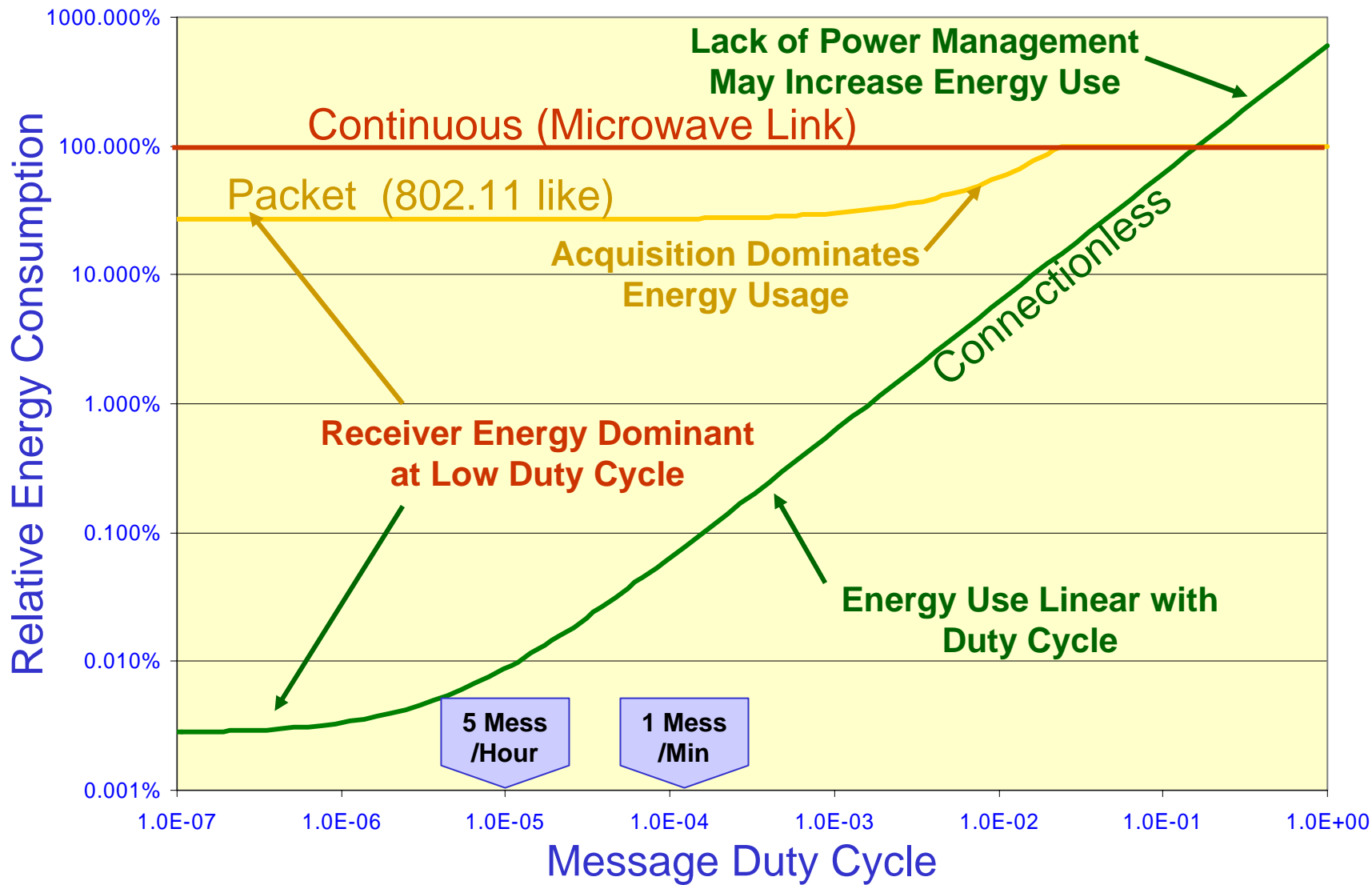



Summary



- IPv6 is Likely Core of Next Decade's Network Structures
- Enhancement in Address Structure and Address Space Opens Up New Opportunities and Issues
 - Mobile, Low Duty Cycle Nodes, MANET, . . .
- IPv6 Ultimate Success Driven by How Fast it Embraces (and Addresses) These Challenges
 - Adaptation Not Limited to Just Core of Packet Definition
- Ongoing DARPA Research May Point to Both Challenges and Solutions
 - Military Needs Likely Foreshadow Civilian Ones